

ICE 823 B Vibratory Hammer

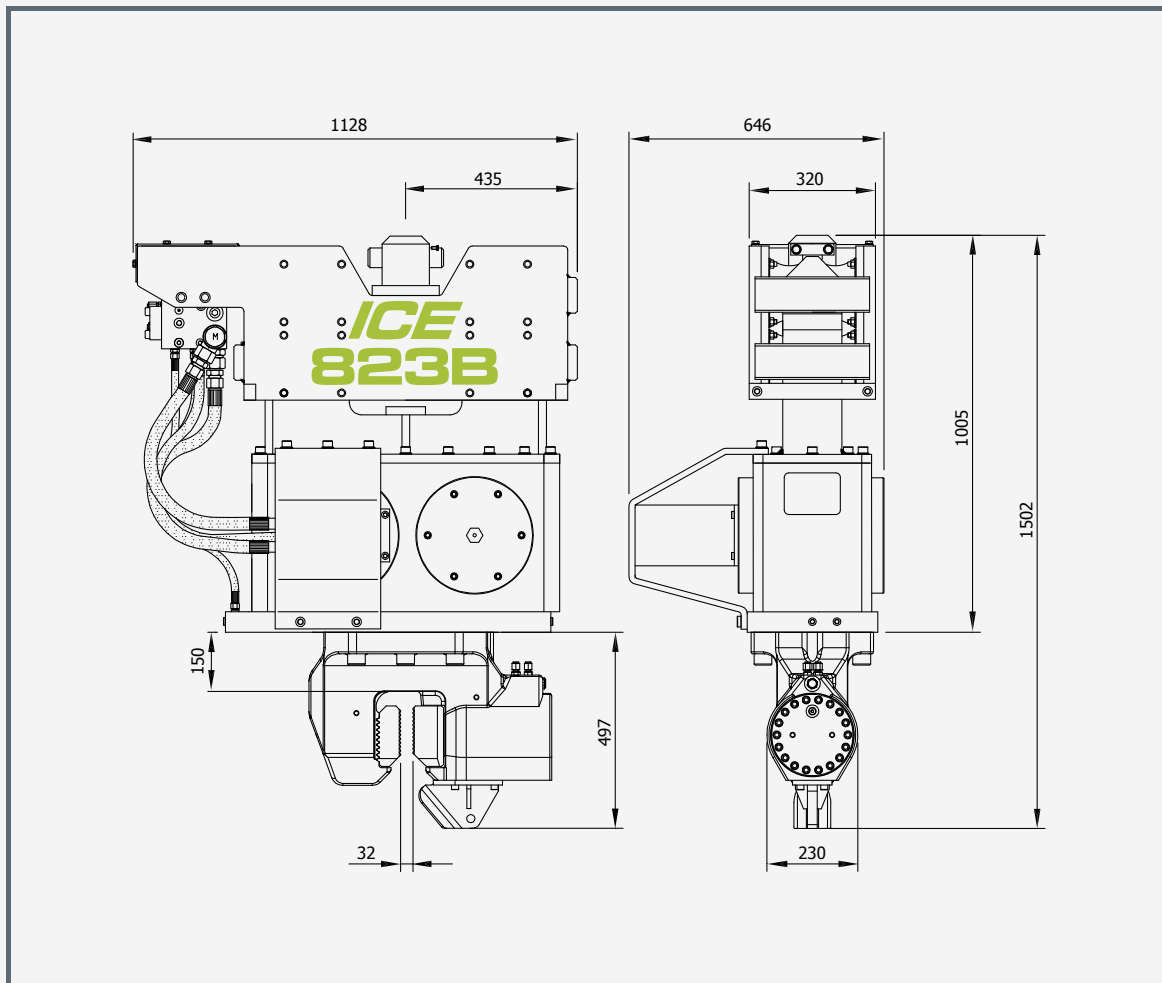

| Specifications | 823B | | Clamps: | |
|-------------------------------------|------|-------|----------------------------|--------|
| Eccentric moment | 8 | kgm | | |
| Max. centrifugal force | 464 | kN | Sheet pile clamp | 60TU |
| Max. frequency | 2300 | rpm | Transport weight per piece | 250 kg |
| Max. amplitude excluding 60TU | 23.2 | mm | | |
| Max. amplitude including 60TU | 17 | mm | | |
| Max. static line-pull | 120 | kN | | |
| Max. operating pressure | 350 | bar | | |
| Max. oil flow | 185 | l/min | | |
| Forced lubrication | no | | | |
| Dynamic weight excluding 60TU | 690 | kg | | |
| Dynamic weight including 60TU | 940 | kg | | |
| Total weight excluding 60TU & hoses | 1060 | kg | | |

ICE 200 RF Hydraulic Power Pack

M200RF / 0212

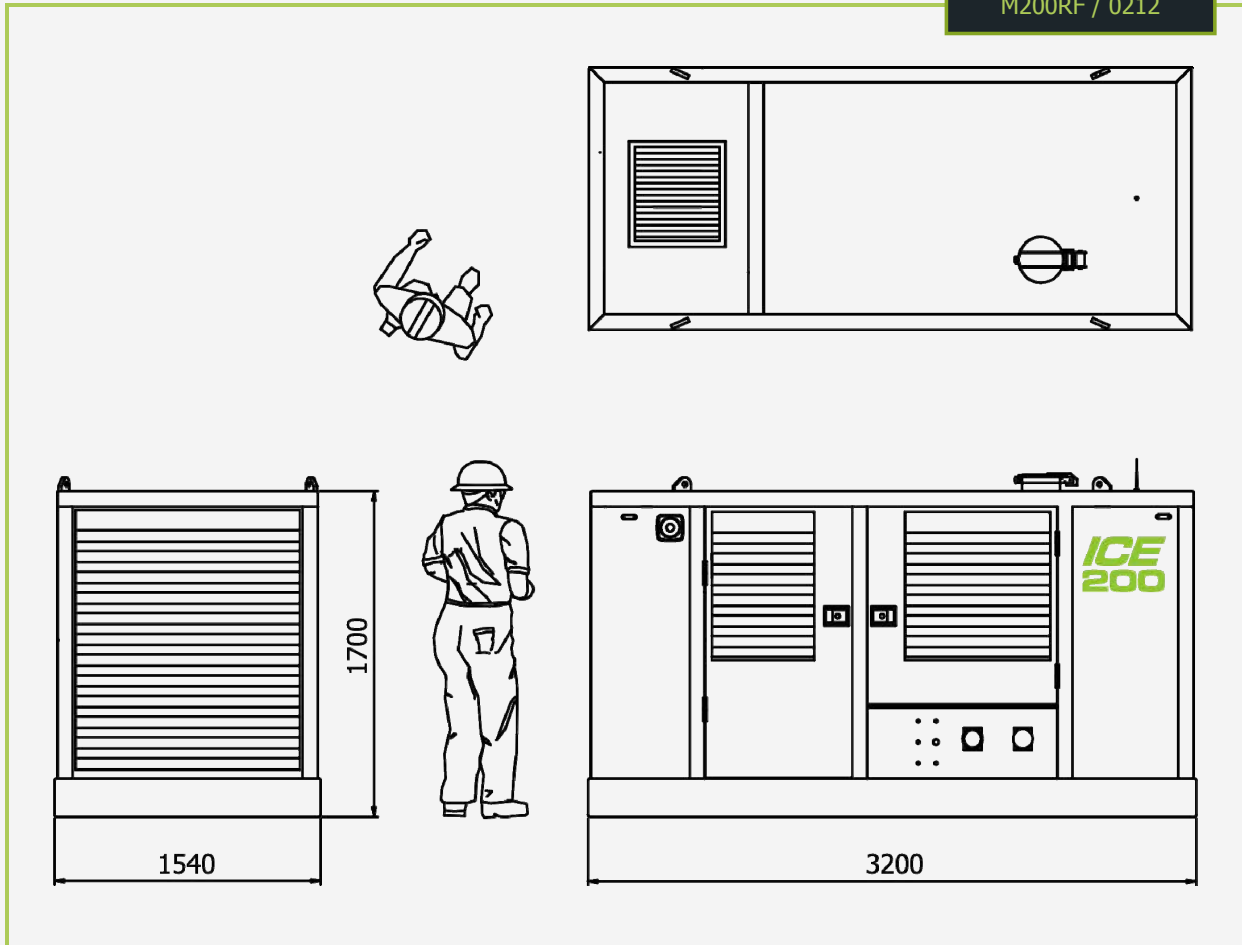

ICE 823 B

ICE 12 RF

| SPECIFICATIONS: | 200RF0005 | 200RF0006 | |
|------------------------|----------------------------|---------------------------|-------------|
| Diesel engine | Caterpillar C6.6 ATAAC | Caterpillar C6.6 ATAAC | |
| Max. theoretical power | 168/225 | 168/228 | kW/HP (DIN) |
| Max. Frequency | 2100 | 2100 | rpm |
| Max. Working pressure | 350 | 350 | bar |
| Hydraulic pump | Bosch-Rexroth A11VLO130 | Parker PVplus140 | |
| Max oil flow | 275 | 295 | l/min |
| Diesel oil | 310 | 350 | l |
| Hydraulic oil | 550 | 550 | l |
| Weight (±) | 3750 | 3750 | kg |

ICE 60 TU Sheet Pile Clamp

ICE 60TU
Sheet Pile Clamp

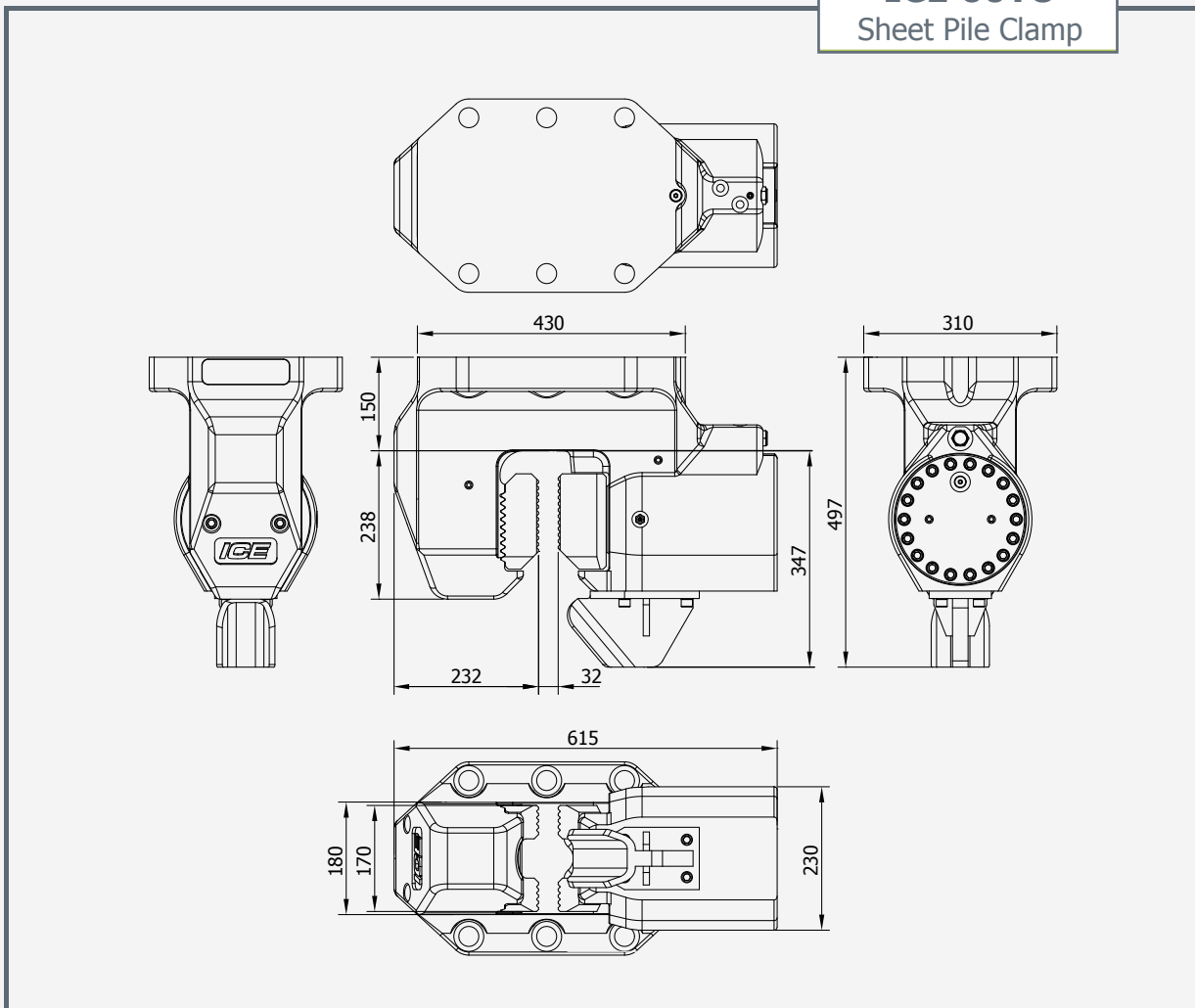

| Specifications | Technische Daten | Spécifications | Specificaties | Especificacions | |
|------------------------|------------------|------------------------|----------------------------|----------------------|--------------------------------|
| Sheet pile clamp | Spundwandzange | Pince palplanches | Damwandklem | Hoja abrazadera pila | |
| Clamping force | 600 kN | Klemmkraft | Force de serrage | Klemkracht | Fuerza de sujeción |
| Max. operating press. | 320 bar | Max. Betriebsdruck | Pression de travail max. | Max. werkdruk | Presión máx. de trabajo |
| Max. clamp open press. | 180 bar | Max. Druck Zange Offen | Pression pince ouvert max. | Max. klem open druk | Presión abrazadera aperto máx. |
| Weight | 250 kg | Gewicht | Poids | Gewicht | Peso |